

Zintra Acoustic Solutions

Cutting and Installation Instructions for ½” panels

CUTTING AND FABRICATING PANELS ON SITE

Any of the panels can be cut or adjusted on site. This allows for site adjustments or adaptations to obstacles (such as fire alarm boxes or electrical boxes.) When cutting or drilling, make sure to use sharpened tools to avoid any overheating of the material. A utility knife with a new blade can also be used.

- The texture of the panels are similar to MDF. A panel may be cut with:
 - Hand saw
 - Use a fine toothed blade. Hold the blade at a low angle. Cut slowly with regular and even strokes.
 - Table saw or Circular saw
 - Allow the panel to pass through the saw with even pressure. Do not force the panel at any time. Use a fine toothed blade with 80 teeth or more. Carbide tipped blades are recommended for extensive cutting or if many panels are to be cut consecutively.
 - Jig saw
 - If adjustable, use a slower speed and steady movement. Select a fine toothed blade suited for finish woods and plastics and use a template for cutouts. Be aware to not overheat an area with any blade.
- Do not attempt to use routers or spiral cutters. Laser tools are also not recommended.
- Best results will be achieved by using only very sharp tools and blades, ensuring clean cutting while not overheating the material during the cut.
- Carefully clamp all panels to avoid vibration during cutting. Vibration during cutting or fabrication may result in panel damage. Properly support the panel at all times.
- Carefully measure all walls to be confident that you can transfer those measurements onto the panels prior to cutting. Scribe to fit as necessary. Use a pencil to mark the panel. If you must mark the face side, use blue tape before marking it. Pencil marks will not erase from Zintra.
- Zintra panels can be drilled. Carbide tipped steel drills are recommended to obtain a high grade finish on the sides of every hole. Better results will be obtained with slow to medium drill speeds.



INSTALLATION

Zintra panels are simple to install. The panels are most commonly installed using one of four methods:

- Direct adhesion to the substrate.
- Using Z clips.
- Using stand-offs.
- Mechanical fasteners (screws and nails).

If you are unsure about which method has been specified for your project, please confirm those details with your specification source and direct your questions to them. MDC may be able to assist you with some common questions, but please realize that your specific project may be unique to you.

Suitable substrates are scuffed MDF, plywood, gyp board, CMU or any uniformly clean, suitably sound, stable, smooth and/or previously painted surface with a verified bond of the coatings and layers with a surface which has some tooth to allow adequate bonding. If you have any doubts about your surface, then a site mock up is suggested. Application to loose or unsecured plywood or MDF panels is not recommended.

Do not rush the installation. A professional installer is recommended so that proper care and attention are paid to this.

Installation details for those four methods:

Direct Adhesion to the Substrate.

- Be certain that your substrate will hold an adequate bond to the recommended adhesive. If in doubt about a coating or a finish already in place, an adhesion mock up test is recommended before you begin.
- Cut, scribe and pre-fit all Zintra ½" panels as necessary.
- Once all of the panels have been properly sized and trimmed, begin the application of the adhesive to the BACK SIDE ONLY of each panel. Use ONLY Liquid Nails LN710 Panel and Molding adhesive tubes.
- Place the cartridge tube into the caulking gun, cut the nozzle and puncture the inner seal. Trim nozzle to produce a ¼" thick bead.
- First, apply a squiggly bead 1" in from the edge of the panel along all four perimeter edges of the BACK face of the panel. See below images for reference.
- Then apply a zig zag pattern diagonally across the central section of the panel, within the already placed bead of adhesive.
- Apply the panel to the substrate within 20 minutes and monitor your adhesive to prevent it from skinning over. Set the panel gently into place.



Toll free 1.800.268.1300 Sans frais 1.800.361.7881
 TORONTO \ 88 Ronson Drive, Etobicoke, Ontario M9W 1B9
 MONTREAL \ 4269 Ste. Catherine Ouest #701 Montreal, Quebec H3Z 1P7
 VANCOUVER \ 611 Alexander Street, Suite 303 Vancouver, British Columbia V6A 1E1

- Smooth the panel into place and then lift it off the surface, holding the panel separate for one minute. Then reset the panel to the substrate, this time applying adequate pressure to firmly set it. Mechanically support the panel(s) if you deem it necessary until the adhesive is completely set.
- NEVER use solvent based contact adhesives or unauthorized adhesives.

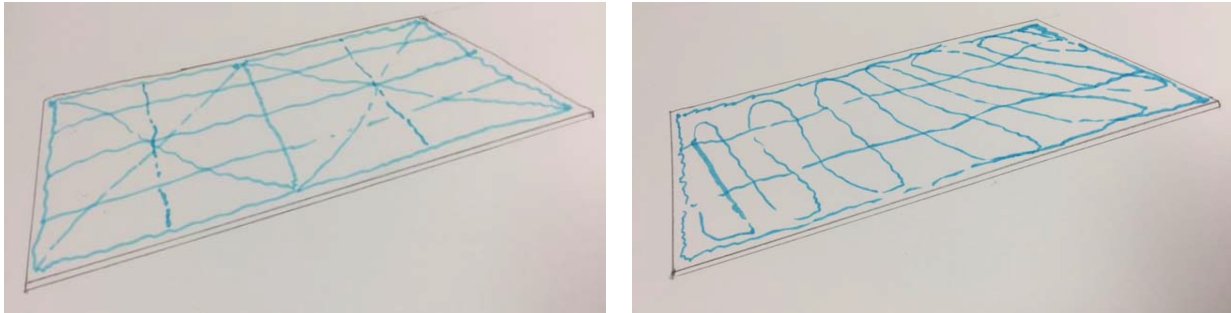

Using Z Clips (also called “2 part French cleats or Z-bars”)

- Z clips are two parts for each clip, one mounted to the wall substrate and the other mounted to the back of the material.
- If using a Z clip system, be sure to allow a gap at the ceiling line which is sufficient in dimension to allow the clip, which will be installed on the panel, to be lifted up over the wall mounted portion of that clip and then dropped in to be seated properly. This is commonly a 1” or so allowance.
- Depending upon the size of your panel, you will have 2, 3 or 4 of the Z clips to mount the panel securely.

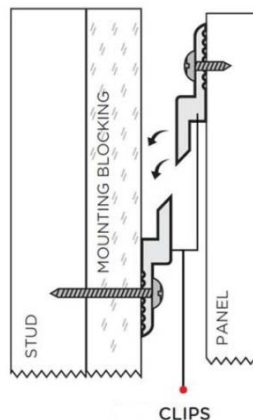

Toll free 1.800.268.1300 Sans frais 1.800.361.7881
 TORONTO 88 Ronson Drive, Etobicoke, Ontario M9W 1B9
 MONTREAL 4269 Ste. Catherine Ouest #701 Montreal, Quebec H3Z 1P7
 VANCOUVER 611 Alexander Street, Suite 303 Vancouver, British Columbia V6A 1E1

- The goal is to mount each panel level and plumb.
- Begin by mounting your first half of each Z clip to the back of the first panel. Orient the clip to be facing downward (open gap is down). Install the uppermost clip no closer than 1" to the horizontal top edge of the panel. Clips should be positioned to be:
 - Parallel to the horizontal edge of the panel.
 - Centered on the panel and no closer than 6" away from each vertical side edge.
 - Separate each clip to be positioned no closer than 2' below the clip above it.
- Attach the panel clip halves to the panel using pan head #8 sheet metal screws, ½" long. You will need to drill holes for these screws in the Z clip halves, but not into the panel itself. Do not overtighten any screws. Position a screw anchor to be no less than every 12" along the clip.
- With each half clip now attached to the panels, you can coordinate the placement of the opposing half of each clip attached to the substrate. **BE SURE YOUR PLACEMENTS ARE DESIGNED TO ALLOW FOR THE DROP IN HEIGHT ALLOWANCE NEEDED TO LIFT THE PANEL OVER THE BOTTOM CLIPS BEFORE SEATING EACH.**
- Measure down from the ceiling on the substrate and position the uppermost clip on a horizontal line which is placed to allow the two halves to be seated properly once the panel is installed. Verify that these clip positions are level and properly spaced to coordinate with the opposing halves before committing.
- Install these clips using a suitable anchor for your substrate. Most commonly, that will be 5/8" gyp board. Select your anchor knowing that the best choice for the screw is a pan or truss head #8 of appropriate length to securely embed into the wall studs. We do not recommend the use of fluted head drywall screws for this. You will need to drill holes for these screws in each of the Z clip halves.
- With the wall halves now secured, you can lift the panel to slip over the wall Z clips and then drop into properly seated position.

Using Stand-Offs

- The number of stand offs will be determined by your panel dimensions. Please refer to the following diagram for an overview of how many that might be. Blocking is also recommended with Stand-Offs as a hidden support to prevent caving of panels.

Stand-off placement guide - Stand-offs should be 3" from the edge of panel

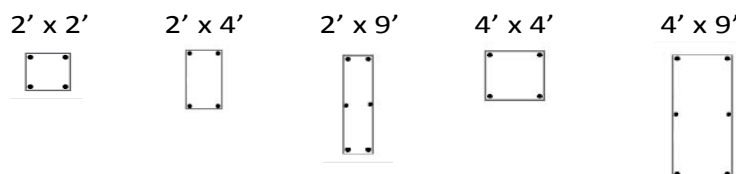

Toll free 1.800.268.1300 Sans frais 1.800.361.7881
 TORONTO 88 Ronson Drive, Etobicoke, Ontario M9W 1B9
 MONTREAL 4269 Ste. Catherine Ouest #701 Montreal, Quebec H3Z 1P7
 VANCOUVER 611 Alexander Street, Suite 303 Vancouver, British Columbia V6A 1E1

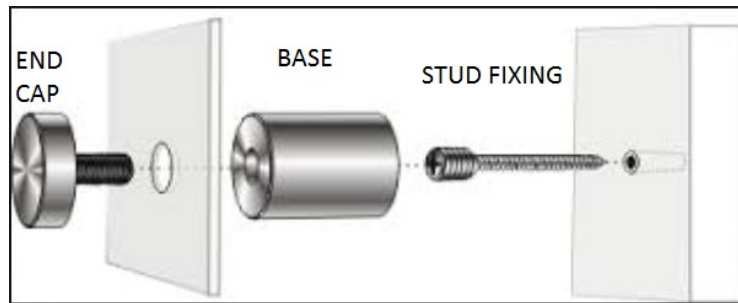

Begin by marking the panel back for the placement of each hole for each stand-off required. No hole should be closer than 3" away from the perimeter edges of the panel.

- Using a tungsten carbide bit of the diameter appropriate to match your stand-off (not supplied, so you will need to determine these), use a power drill to create each hole as you have marked.
- With all of the holes now drilled, determine the precise placement of where the panel is to be installed. With one person holding the panel level and plumb, a second person will mark the substrate for the precise placement of the holes.
- Secure each stand-off base to the substrate using an appropriate anchor. (We recommend that you have arranged a backing support already in the wall or align a vertical column of anchors to fall on a wall stud instead of hanging the full weight off just the gyp board wall panel. The installer or specifier will be making these choices.)
- Set the panel in place over the stand-off bases and attach the stand-off head cap trims to secure the panel. Tighten only by hand, do not over tighten.

Mechanical Fasteners

- You may also secure the Zintra panel to the substrate using the same fastener placement guide as used for the stand-offs, but use direct fastening (screw or nails) to secure the panel.
- If using screws, we suggest that you use a pan or truss head and that you pre-drill your holes (selecting a tungsten carbide drill bit of the appropriate diameter to the screw you have selected.) Remember to select an anchor which is appropriate to your substrate. Each standard Zintra panel is approximately 18 lbs.
- Make sure to tighten all screws to be tight, but to not be overly tight (do not compress the Zintra unevenly.)
- Power nailing can be utilized if you have adjusted the tip of the gun for the density of the Zintra.

If you are unsure about the system selected for your project, please stop and verify the details. MDC may be able to assist you with some methods of common attachment, but others may be unique to your project.



Toll free 1.800.268.1300 Sans frais 1.800.361.7881
 TORONTO 88 Ronson Drive, Etobicoke, Ontario M9W 1B9
 MONTREAL 4269 Ste. Catherine Ouest #701 Montreal, Quebec H3Z 1P7
 VANCOUVER 611 Alexander Street, Suite 303 Vancouver, British Columbia V6A 1E1